

## Home/Office Wiring Guide

For connecting TalkSwitch 24 and 48-LS phone systems to residential buildings.

### Table of Contents

#### Basic Residential Phone Wiring

- Looped Wiring
- Single Line Wiring
- Dual Line Wiring
- Single Line RJ-11
- Dual Line RJ-11
- Standard Phone Cord
- Demarcation Point

#### Home and Home Office Wiring Options

##### Wiring Option #1

- Connecting to Phone Lines
- Connecting to TalkSwitch

##### Wiring Option #2

- Re-Wiring Demarcation Point
- Adding Extension Block
- Connecting To TalkSwitch

## Basic Residential Phone Wiring

### Looped Wiring

Loop wiring is common in most residential houses. The demarcation point breaks the incoming phone lines into 'loops' that can run the length of the entire house, but are often broken into smaller loops that serve different areas of the house.

As expected, all houses have one phone line, however it is also common to have two or more incoming phone lines. Whether you are wiring single, dual or multiple lines, you will still be using phone cord with 4 wires. How each phone jack is wired to the loops will determine if the phone jack is on line 1 or line 2.

This document will discuss only single and dual line wiring configurations. However, many of the processes can be applied to multi-line wiring.

### Residential Building

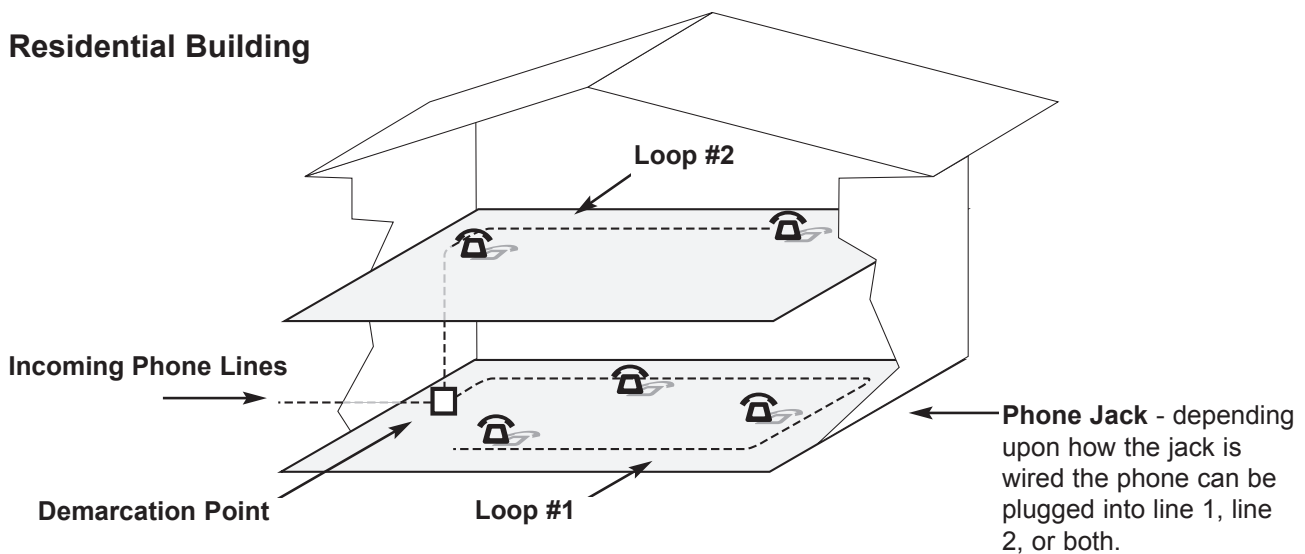

### Single Line Wiring

For a single incoming phone line, all phones in the building will usually be wired using the RED and GREEN wires of the phone cord. The other two wires, black and yellow, are not used.

The demarcation point connects the incoming RED and GREEN pair to various loops within the building. It is probable that the building is also wired with a BLACK and YELLOW pair, however these are not connected to any wall jacks.

### Dual Line Wiring

Two incoming phone lines are denoted in pairs, usually the RED and GREEN are used as line 1, and the BLACK and YELLOW are line 2. All four wires are looped throughout the building so that each jack has access to line 1 and line 2. How each jack is connected to the RED, GREEN, BLACK, and YELLOW wires determines if it is connected to line 1, line 2, or both.

#### Standard Phone Cord

Standard phone cord is usually grey in colour and carries 4 wires. Green and Red wires are used for line 1, and Yellow and Black are used for line 2.

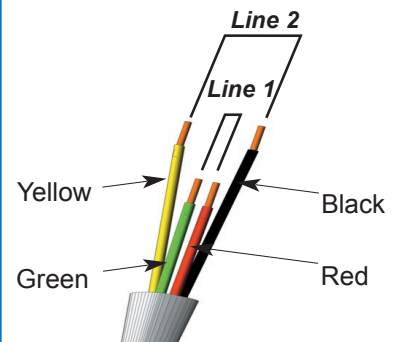

## Basic Residential Phone Wiring

### Single Line RJ-11

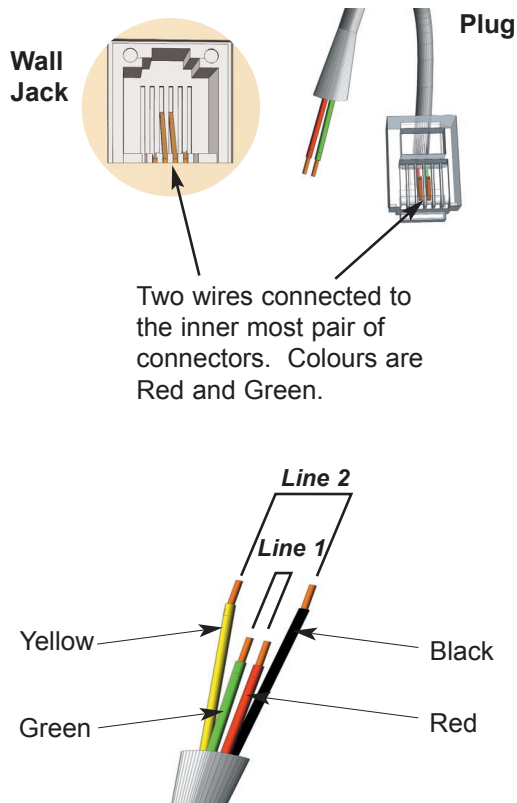

### Dual Line RJ-11

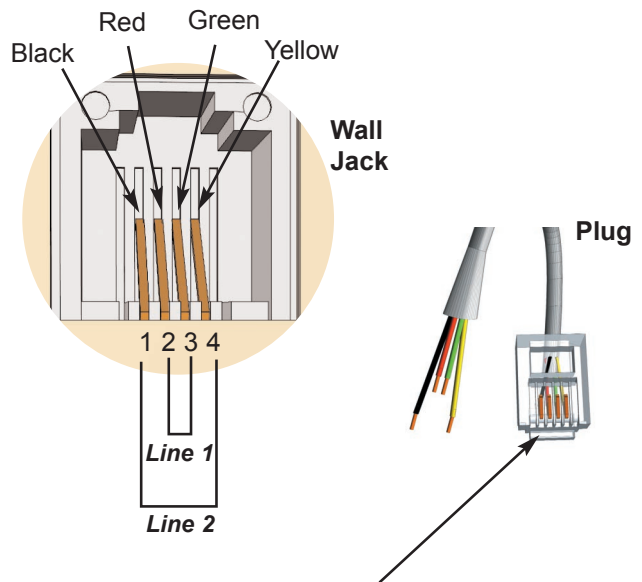

Four wires connected to the inner most four of connectors.

Line 1: Inside pair - Red & Green  
Line 2: Outside pair - Yellow & Black

### Demarcation Point

The demarcation point is the point of interconnection between the telephone company facilities and your building.

**Location:** It is usually a box located within the building and within 15 feet of the incoming phone wiring. In newer houses, it may be located near the fuse box.

**Wiring:** The box will contain at least 4 posts used to branch the incoming wiring to the internal phone wiring. The 'red' post should have all the red wires attached to it, the 'green' should have all the green wires attached etc.

This demarcation point shows two lines (4 wires) wired as two loops.

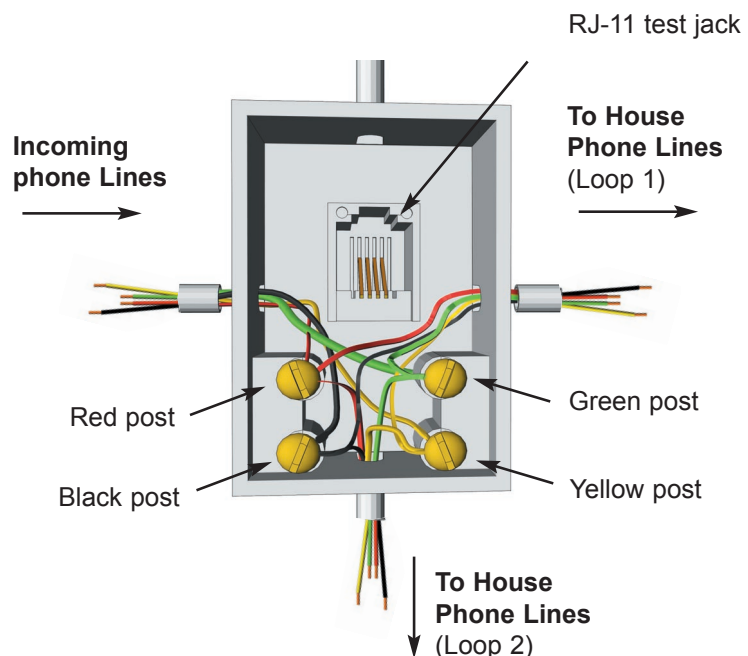

## Home and Home Office Wiring Options

### Prior to adding TalkSwitch

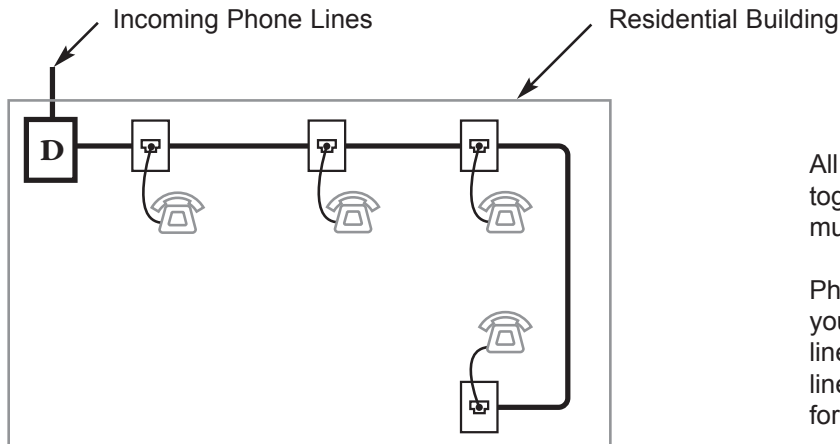

All phones are connected together in a single loop (or in multiple loops)

Phones are all wired to line 1. If you have two or more incoming lines, the phones can be wired to line 1, line 2 or even both lines for dual line phones.

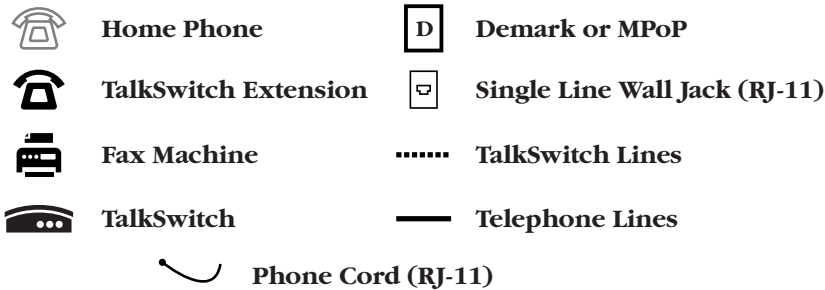

Prior to adding a TalkSwitch, all phones in the home ring in unison when a call comes in. Home phones do not have TalkSwitch functionality and rely on phone company features for any enhancements.

When adding a TalkSwitch the method of directing phone calls depends upon how the phones are wired and how the software is set up.

**You must first choose a wiring method (Option #1 or Option #2) below that best suits your needs, and your wiring ability.**

## Home and Home Office Wiring Options

### Option #1

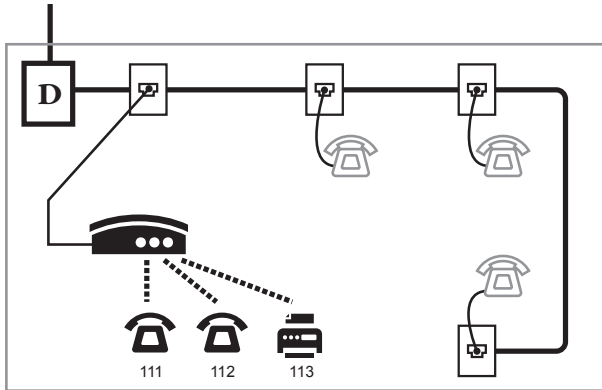

- ▶ One incoming phone line.
- ▶ TalkSwitch Phones are separate from the home phones.
- ▶ Home phones and office phones ring at the same time on incoming lines.

#### Advantages:

- Easy to wire and set up

Note: You can still use some of TalkSwitch's features from the home phones. See section 3.2.8 of the User Guide for more details.

#### Disadvantages:

- Your home phones and office phones are not fully integrated together. For example, calls to the office cannot be forwarded to the home phones.
- Home phones don't have access to voicemail and other TalkSwitch features.

See "Wiring Option #1"

### Option #2

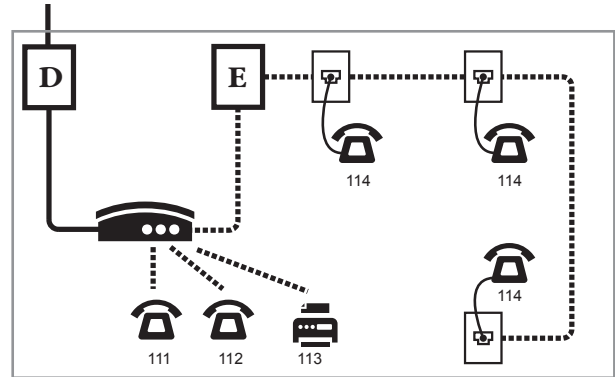

- ▶ One or Two incoming phone lines.
- ▶ TalkSwitch controls all of the incoming phone lines.
- ▶ All Phones are controlled by TalkSwitch.

#### Advantages:

- Home phone system and office phone system are integrated together.
- Calls to the home can be forwarded to the office and vice versa.
- The home phones have all the call handling capability as the office phones including voicemail, call cascade, mode scheduling, call forwarding etc.

#### Disadvantages:

- Requires a little more wiring, and additional cabling. However this step-by-step guide should take care of it all.

See "Wiring Option #2"

## Wiring Option #1

### Connecting to Phone Lines

#### Using One Phone Line

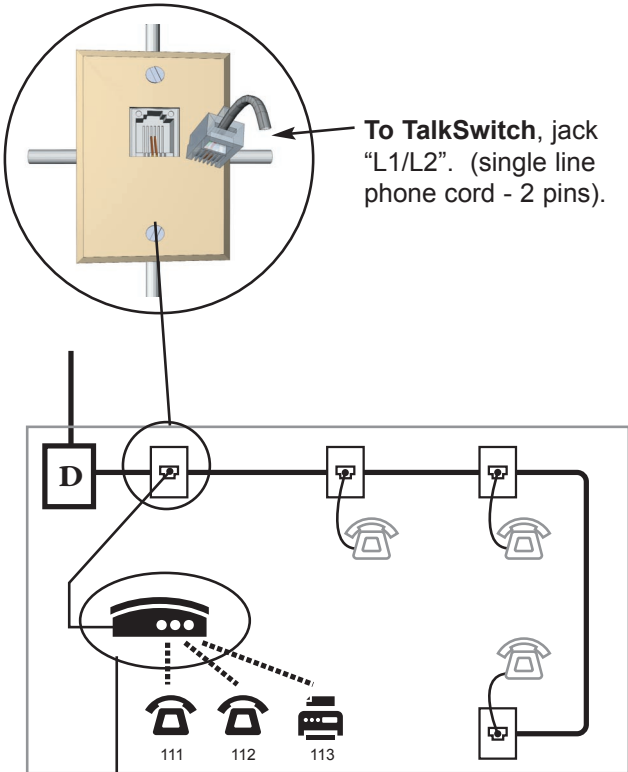

#### Using Two Phone Lines

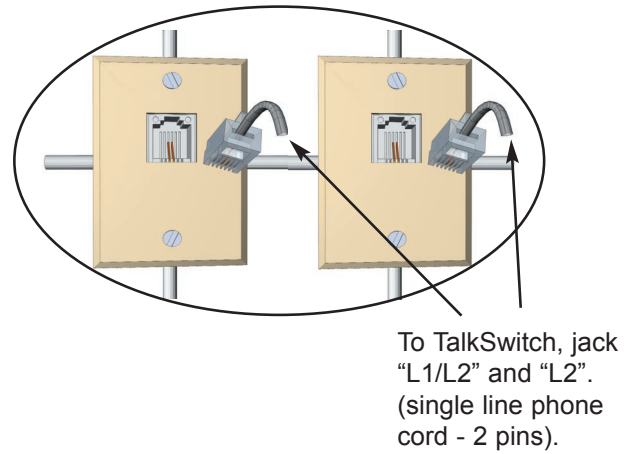

#### Using a Dual Line Phone Jack

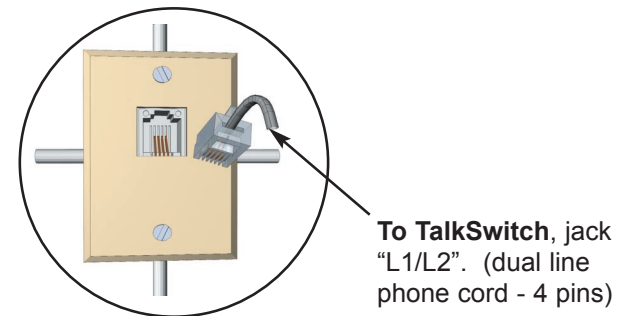

### Connecting to TalkSwitch

#### TalkSwitch Rear Panel

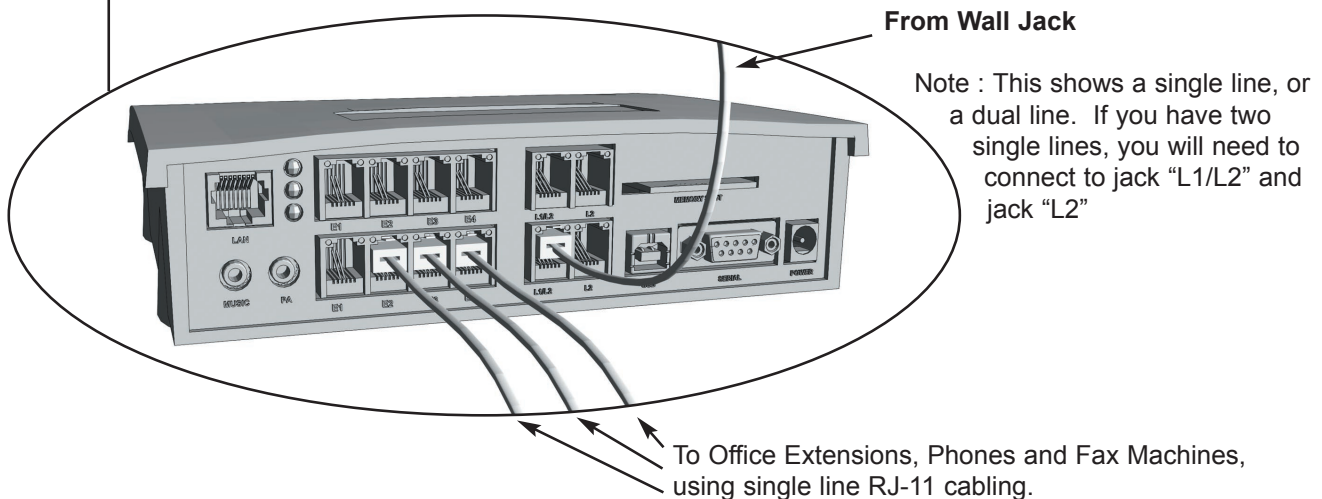

## Wiring Option #2

### Re-Wiring Demarcation Point

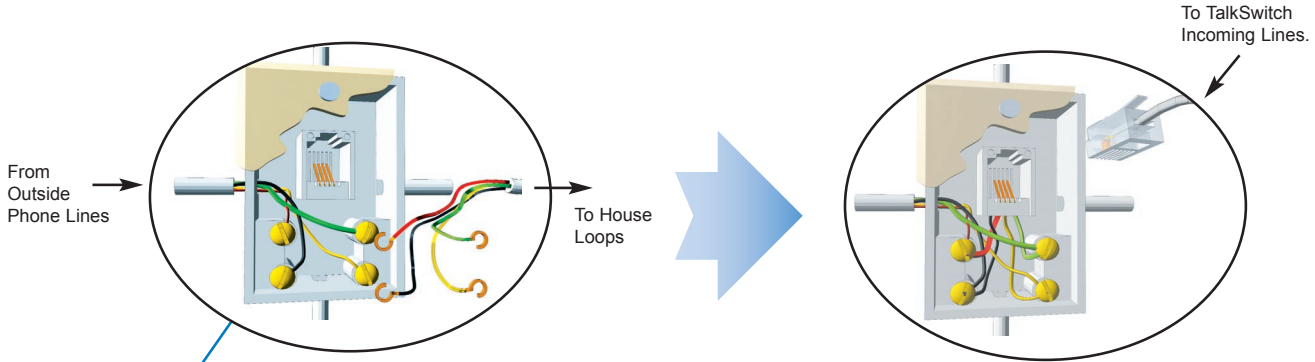

**Step 1:** Remove wiring to house loops. Disconnect any additional house loops that may also be connected. Only one loop wiring is shown for clarity.

**Step 2:** Tighten the screws connecting the incoming wires to their respective posts.

**Step 3:** Use an RJ-11 (single line or dual line) to connect to the TalkSwitch. Plug the RJ-11 into Jack "L1/L2"

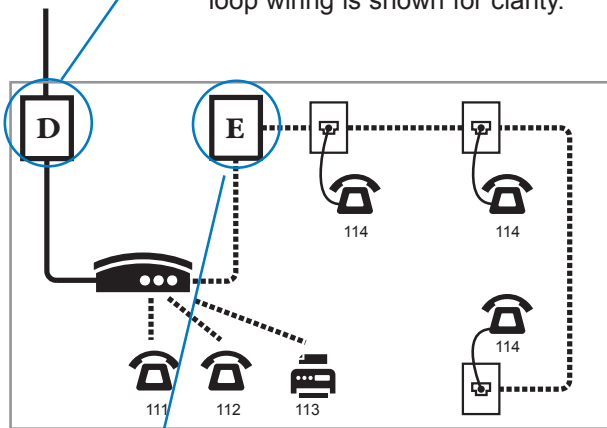

### Adding Extension Block

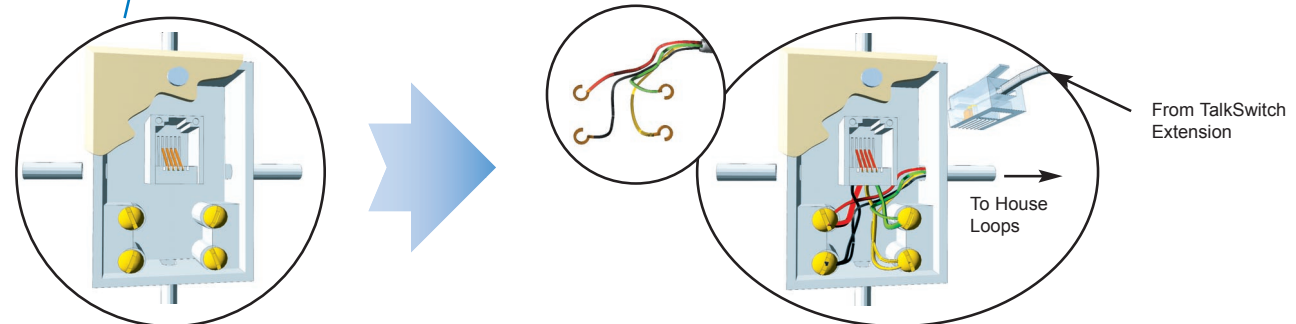

**Step 1:** Add an Extension Block next to the previous demarcation point.

**Step 2:** Take the previous house loop wiring and connect them to the four posts of the extension block.

**Step 3:** Use an RJ-11 (single line) to connect from the TalkSwitch. Plug the RJ-11 into a TalkSwitch Extension, jack "E1" through "E8"

## Connecting to TalkSwitch

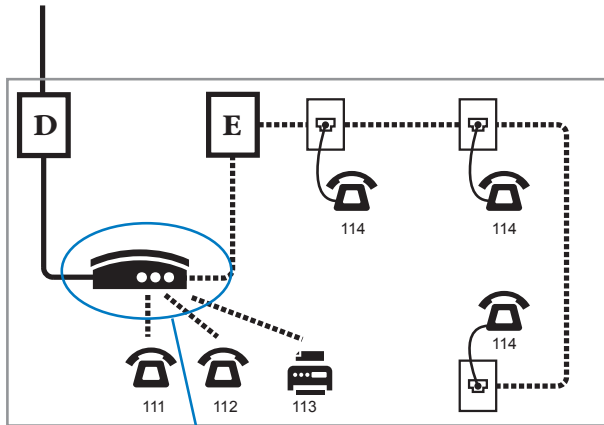

### Step 1:

Use dual line phone cable to connect from the Demarcation Point to TalkSwitch. You will need to purchase the dual line phone cable or wire it and crimp it yourself. Do not use the supplied RJ-11 cable as it is only single line.

### Step 2:

Use the single line RJ-11 phone cord supplied with TalkSwitch to connect from the TalkSwitch Extension to the Extension Block.

### Step 3:

Connect the office phones to the TalkSwitch using RJ-11 cabling supplied with TalkSwitch or the cables supplied with your phone.

**To Extension Block**

Use a single line phone cable from jack "E4"

**From Demark point**

Use a 2 line phone cable from the demark point to jack "L1/L2".

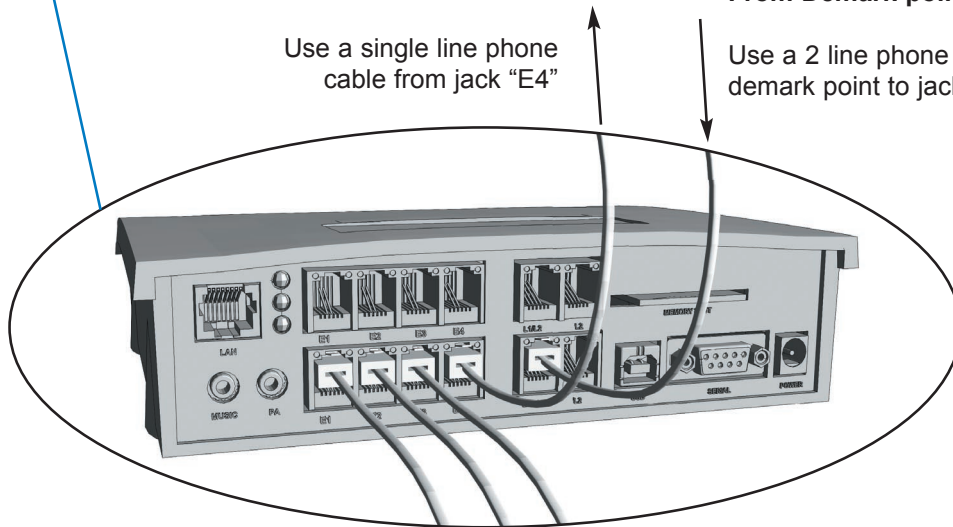

RJ-11 cabling can go up to 100 feet from the TalkSwitch without affecting voice quality. You may extend the lines farther although you may suffer voice quality.

Cabling can be run along baseboards, moldings, threaded between walls, and hidden under carpets. Keep the cords in corners and along edges help hide it and avoid high traffic areas.

To Office Extensions, Phones and Fax Machines

**Ext 113:** To Fax Machine (optional) from jack "E3"

**Ext 112:** To Phone from jack "E2"

**Ext 111:** To Phone from jack "E1"